

Confirming workpiece on a removable robot hand

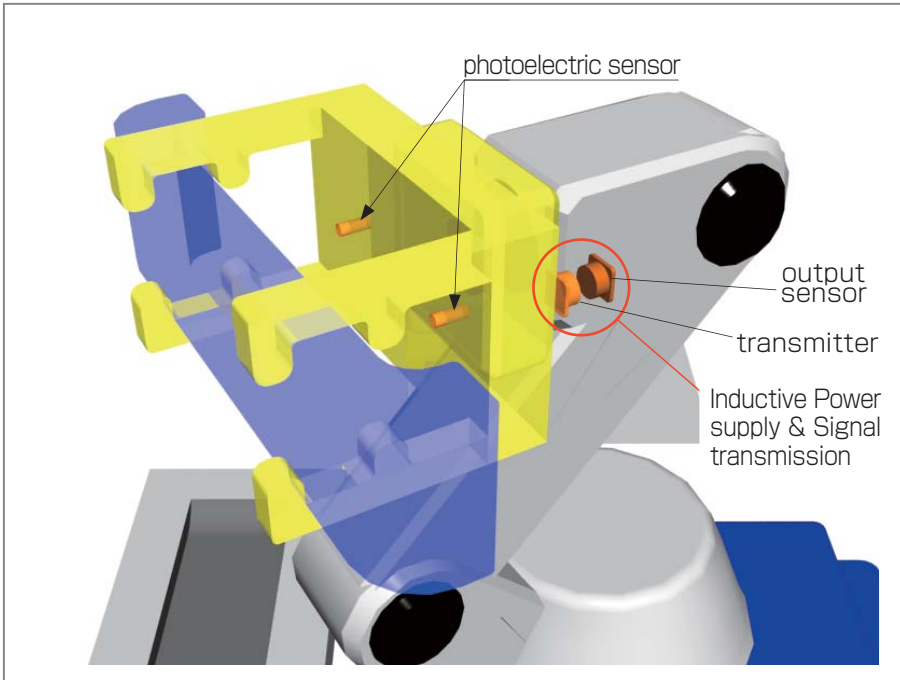

Previous problems

- Manual exchange of the hands by operator is required.
- Coiled cables used were breaking from motion stress.

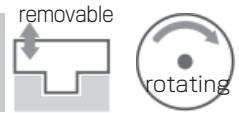

After improvement

- Eliminated manual exchange process by an operator.
- Eliminated coiled cable, Eliminated cable breakage problem.

Application

Confirming presence of workpiece in a robot hand picking up workpieces from a die. The robot hand rotates and replaced for the shapes of the workpiece. Remote System sends power to photoelectric sensors and transmits their signal.

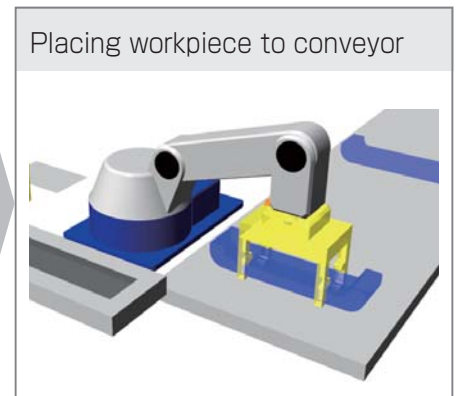
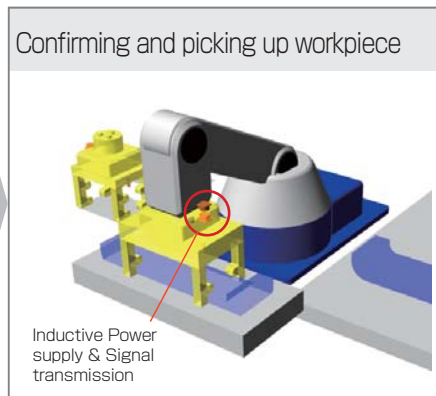
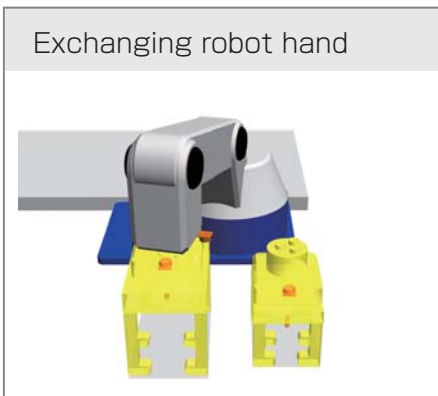

Construction of devices

