

Confirming work piece on a removable robot hand

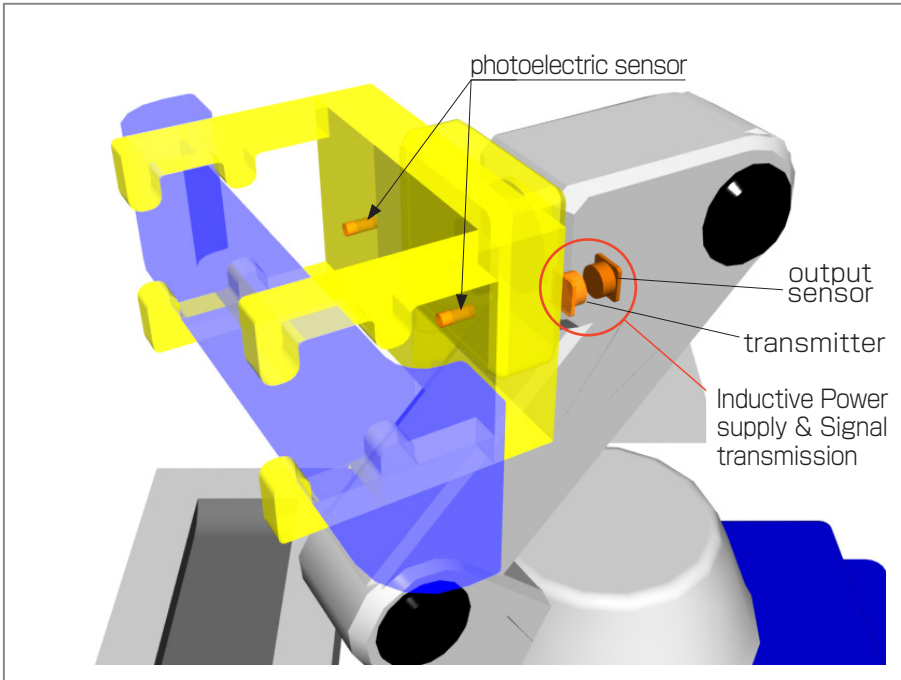

Previous problems

- Manual exchange of the hands by operator is required.
- Coiled cables used were breaking from motion stress.



After improvement

- Eliminated manual exchange process by an operator.
- Eliminated coiled cable, Eliminated cable breakage problem.

Application Confirming presence of work piece in a robot hand picking up work pieces from a die. The robot hand rotates and replaced for the shapes of the work piece. Remote System sends power to photoelectric sensors and transmits their signal.

