

Work piece detection on a turntable

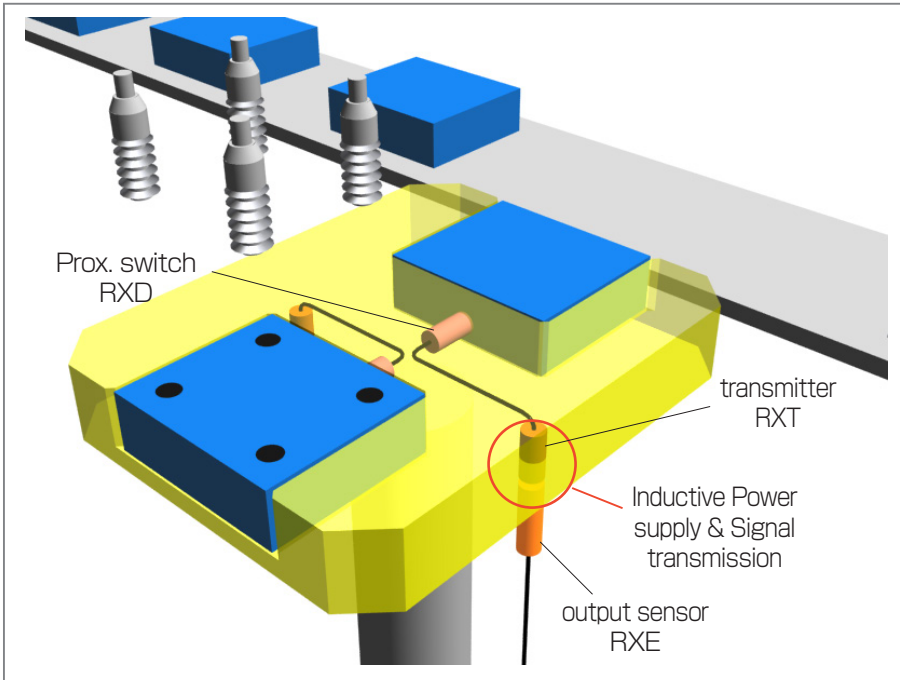

Previous problems

- Cable breakages from stress



After improvement

- Eliminated stress points, eliminated cable breakage problems.
- Free from limitation of cable movement, no need to return to the home position.

Application Machining and loading/unloading are performed continuously by turning the turntable which has two jigs
 Remote System supplies power to proximity switched and transmits the switching state of the sensor.

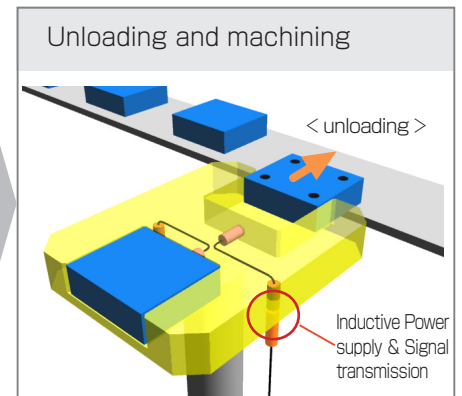
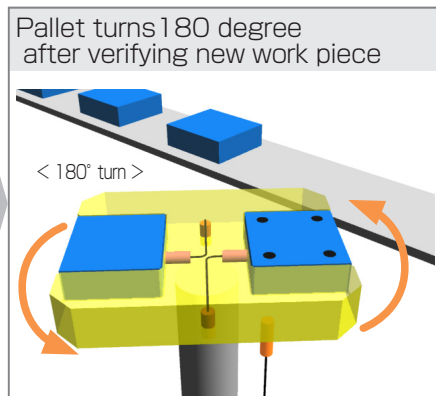
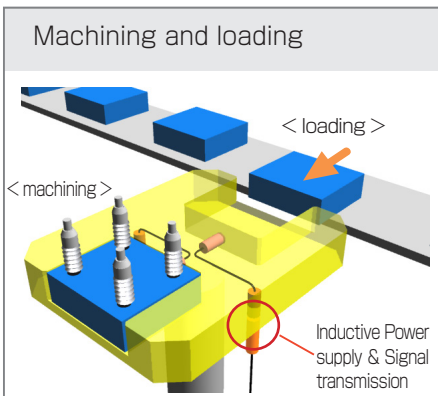

Construction of devices

