

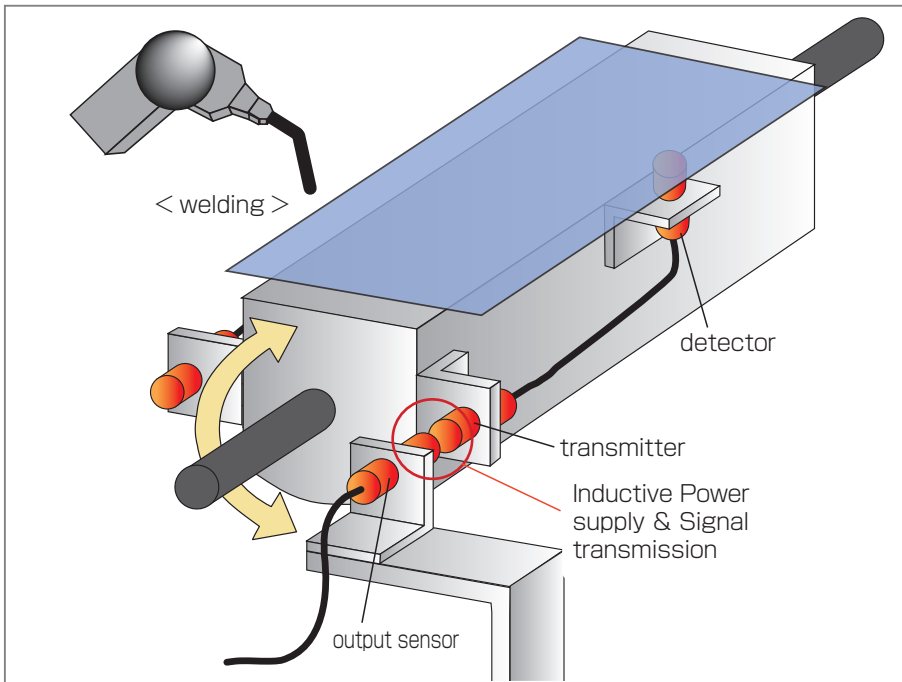

# Confirming presence of work piece on a two sided jig



**Previous problems**

- Cable breakages due to turning stress



**After improvement**

- Eliminated stress points, eliminated cable breakage problems.
- Also contributed to space saving inside of the machine.

**Application** Two sided jig is used to accept different profile of work piece. Remote System supplies power to proximity switch for detection and transmits the switching state of sensor.

