

Confirming work piece on a removable jig

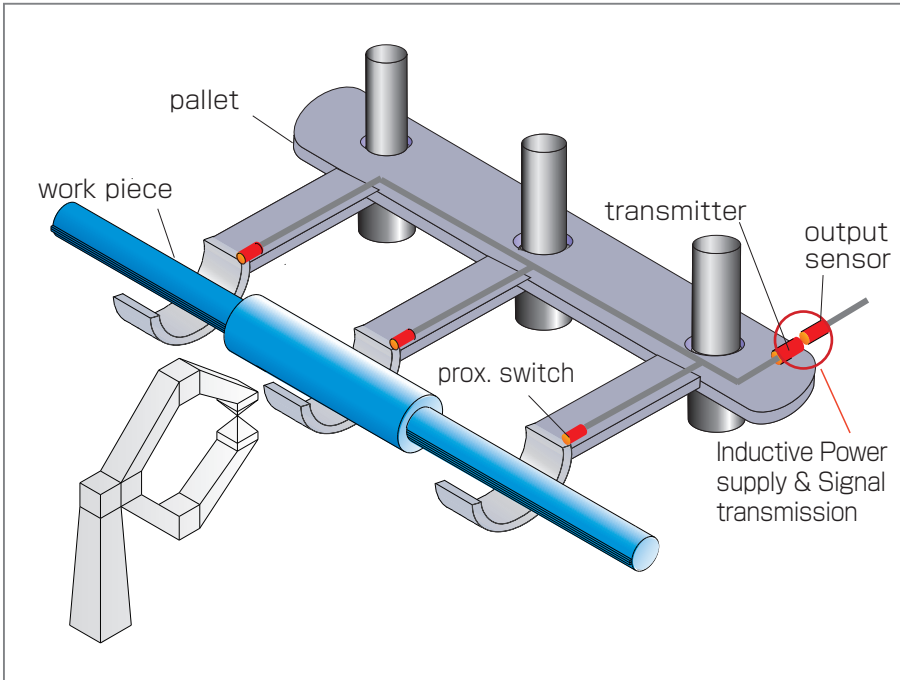

Previous problems

- Manual disconnection and connection of the connectors required for every jig replacement.

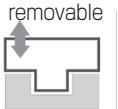

After improvement

- Eliminated connection process.
- Faster change out time.
- Eliminated wear and tear components.

Application

Replace welding jig according to the shape of the work piece.
 Confirm the seating of the work piece, and weld.
 Remote system sends power to proximity switches and transmits their switching state.

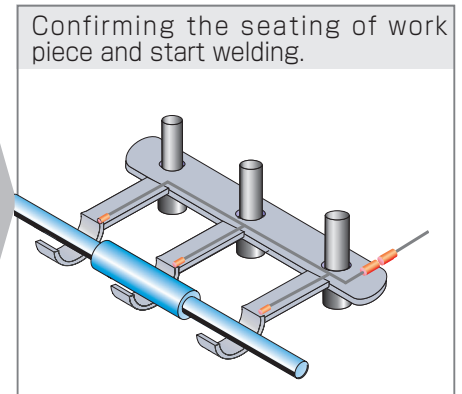
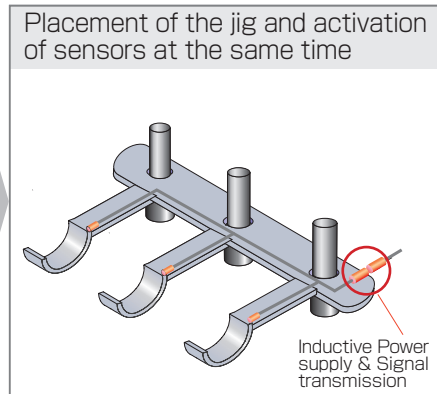
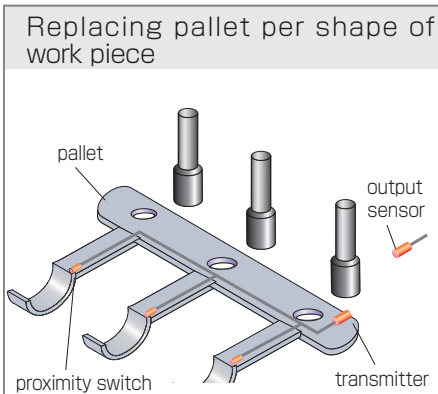

Construction of devices

